



**CORE BORE**

**PARTS LIST**

**OPERATORS MANUAL**

**MODEL**  
**CB733**

**SEPTEMBER, 2024**



## Table of Contents

<u>Description</u>	<u>Page No.</u>
1. Specifications .....	4-5
2. General Safety Rules .....	6-8
3. Operating Instructions .....	9-18
4. Wiring Diagram .....	19
5. CB733 Exploded View .....	20
6. CB733 Parts .....	21-22
7. CB733 Tools .....	23
8. Notes .....	24
9. Warranty .....	26

# Original instructions



(115V)

CECB

# DIAMOND CORE DRILLING MACHINE

**CAUTION:**

Machine equipped with overheat thermal protection. When the thermal protection kicks in, always remove from the workpiece and run at no load for at least 3 minutes to allow motor to cool before returning to operation.

**SPECIFICATIONS**

Model	CB733(115V)
Power Input	3000W / 20 amp
Voltage	115V~60Hz
No Load Speeds min <sup>-1</sup>	550 / 1000 / 1600
Rated Load Speeds min <sup>-1</sup>	345 / 630 / 1000
Drilling Capacity	12" (250mm), Max. 16" (400mm)
Dimensions	21.7" x 6.1" x 8.3"
Gear Oil Type	90W SHELL SPIRAX A80/90
Gear Oil Capacity	625ml (21.1 oz)
Spindle Thread	1-1/4" UNC male, 1/2" BSP female
Protection Class	Class 1
Weight	12.9kg (28.4 Lbs)

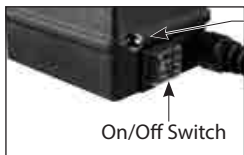
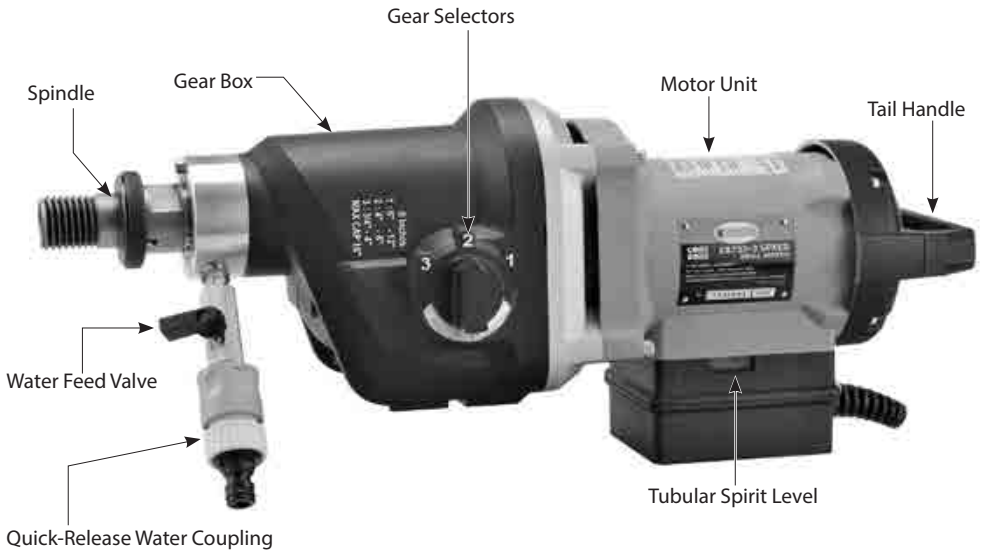

LED Load Warning & Brush Wear Indicator Lamp

## GENERAL SAFETY INSTRUCTIONS



**WARNING** Read all safety warnings and all instructions. Failure to follow the warnings and instructions may result in electric shock, fire and/or serious injury.

Save all warnings and instructions for future reference.

The term "power tool" in the warnings refers to your mains-operated (corded) power tool.

### 1) Work area safety

- a. **Keep work area clean and well lit.** Cluttered or dark areas invite accidents.
- b. **Do not operate power tools in explosive atmospheres, such as in the presence of flammable liquids, gases or dust.** Power tools create sparks which may ignite the dust or fumes.
- c. **Keep children and bystanders away while operating a power tool.** Distractions can cause you to lose control.

### 2) Electrical safety

- a. **Power tool plugs must match the outlet. Never modify the plug in any way. Do not use any adapter plugs with earthed (grounded) power tools.** Unmodified plugs and matching outlets will reduce risk of electric shock.
- b. **Avoid body contact with earthed or grounded surfaces, such as pipes, radiators, ranges and refrigerators.** There is an increased risk of electric shock if your body is earthed or grounded.
- c. **Do not expose power tools to rain or wet conditions.** Water entering a power tool will increase the risk of electric shock.
- d. **Do not abuse the cord. Never use the cord for carrying, pulling or unplugging the power tool. Keep cord away from heat, oil, sharp edges or moving parts.** Damaged or entangled cords increase the risk of electric shock.
- e. **When operating a power tool outdoors, use an extension cord suitable for outdoor use.** Use of a cord suitable for outdoor use reduces the risk of electric shock.
- f. **If operating a power tool in a damp location is unavoidable, use a residual current device (RCD) protected supply.** Use of an RCD reduces the risk of electric shock.

### 3) Personal safety

- a. **Stay alert, watch what you are doing and use common sense when operating a power tool. Do not use a power tool while you are tired or under the influence of drugs, alcohol or medication.** A moment of inattention while operating power tools may result in serious personal injury.
- b. **Use personal protective equipment. Always wear eye protection.** Protective equipment such as dust mask, non-skid safety shoes, hard hat, or hearing protection used for appropriate conditions will reduce personal injuries.
- c. **Prevent unintentional starting. Ensure the switch is in the off-position before connecting to power source and/or battery pack, picking up or carrying the tool.** Carrying power tools with your finger on the switch or energising power tools that have the switch on invites accidents.
- d. **Remove any adjusting key or wrench before turning the power tool on.** A wrench or a key left attached to a rotating part of the power tool may result in personal injury.
- e. **Do not overreach. Keep proper footing and balance at all times.** This enables better control of the power tool in unexpected situations.
- f. **Dress properly. Do not wear loose clothing or jewellery. Keep your hair, clothing and gloves away from moving parts.** Loose clothes, jewellery or long hair can be caught in moving parts.

- g. **If devices are provided for the connection of dust extraction and collection facilities, ensure these are connected and properly used.** Use of dust collection can reduce dust-related hazards.

#### 4) Power tool use and care

- a. **Do not force the power tool. Use the correct power tool for your application.** The correct power tool will do the job better and safer at the rate for which it was designed.
- b. **Do not use the power tool if the switch does not turn it on and off.** Any power tool that cannot be controlled with the switch is dangerous and must be repaired.
- c. **Disconnect the plug from the power source and/or the battery pack from the power tool before making any adjustments, changing accessories, or storing power tools.** Such preventive safety measures reduce the risk of starting the power tool accidentally.
- d. **Store idle power tools out of the reach of children and do not allow persons unfamiliar with the power tool or these instructions to operate the power tool.** Power tools are dangerous in the hands of untrained users.
- e. **Maintain power tools. Check for misalignment or binding of moving parts, breakage of parts and any other condition that may affect the power tool's operation. If damaged, have the power tool repaired before use.** Many accidents are caused by poorly maintained power tools.
- f. **Keep cutting tools sharp and clean.** Properly maintained cutting tools with sharp cutting edges are less likely to bind and are easier to control.
- g. **Use the power tool, accessories and tool bits etc. in accordance with these instructions, taking into account the working conditions and the work to be performed.** Use of the power tool for operations different from those intended could result in a hazardous situation.

#### 5) Service

**Have your power tool serviced by a qualified repair person using only identical replacement parts.** This will ensure that the safety of the power tool is maintained.

#### Symbols used in this manual

V.....volts

A.....amperes

Hz.....hertz

W.....watt

~.....alternating current

$n_0$ .....no load speed

$\text{min}^{-1}$ .....revolutions or reciprocation  
per minute

 .....warning of general danger

 .....with electrical earth

 .....read these instructions

 .....always wear eye protection

 .....always wear a dust mask.

 .....always wear hearing protection

 .....wear safety-approved hard hat

 do not dispose of electric tools,  
accessories and packaging together  
with household waste material

## Drill safety warnings

- **Use auxiliary handle(s), if supplied with the tool.** Loss of control can cause personal injury.
- **Hold power tool by insulated gripping surfaces, when performing an operation where the cutting accessory may contact hidden wiring or its own cord.** Cutting accessory contacting a "live" wire may make exposed metal parts of the power tool "live" and could give the operator an electric shock.
- **The locking screw for the ground/earth cable may never be loosened, otherwise there is acute danger to life!**
- **Check the ground (earth) connection of the electrical plug.**
- **Never use the machine without a GFCI or PRCD fault-current safety switch.**
- **Ensure that no water is allowed to get into the motor unit during operation.**
- **If you detect a leak in any part of the water supply system, shut the machine down immediately and repair the fault. Water pressure should not exceed 70 psi (4 bar).**
- **Take care not to damage gas, water, power and other conduits in the area of the drilling operation.** Drain or shut off these conduits as required.
- **Block off the working area and place warning signs on both sides of the wall when drilling through from one side to the other.**
- **Take appropriate precautions to ensure that, in the event of a drilling core dropping out, no personal injury or material damage will result.**
- **When drilling hollow components, check the flow route of the cooling water in order to prevent damage.**
- **WARNING: Pull the plug out of the socket before making device settings or changing accessories.** Many accidents are caused by accidental starting of power tools.
- **When mounting the stand, fix the base to a firm, level, surface or wall.** The power tool cannot be guided evenly and safely if the base can slip or shake.
- **This diamond core drill cannot be used for overhead drilling.**

**WARNING: Hazardous situation due to broken parts: Always check core bits before using. Deformed or damaged drill core bits must not be used;**

**WARNING: Use of non-recommended cutting tools can lead to injuries due to the loss of control. Only use drill core bits designed for this machine only. Follow the minimum and maximum diameter given on the specifications page and do not exceed the length of the core bits beyond the maximum allowed by the drill stand. (This is usually 24" or 750mm)**

**WARNING: Incorrect clamping and positioning of the drill core bit may lead to dangerous situations by broken and ejected parts of the drill core bit. Core bits must be assembled correctly. Follow the instructions below under "Fastening the Core Bit"**

**WARNING: It is necessary to always wear suitable personal protective equipment, including:**

- **Hearing protection, to reduce the risk of induced hearing loss,**
- **Gloves, when handling core bits or rough materials, to reduce injuries by sharp edges,**
- **Safety glasses, to prevent injuries by flying particles,**
- **Non-slipping footwear, to prevent injuries caused by slippery surfaces;**

**WARNING: A wrongly assembled machine may cause a hazardous situation. Follow the instructions provided with the drill stand on how to fix the machine into the stand and fixing to the material to be drilled; See also the instructions below under "Mounting to a Drilling Stand"**



## INTRODUCTION

This machine is for the intended purpose of diamond core drilling of concrete, masonry, stone and similar materials. It must always be mounted on a drilling stand. This machine is for professional use only and only trained personnel may operate this machine.

All other uses which are not for the intended purpose are prohibited.

It is equipped with a water feed system which is required for the diamond core drilling process. A GFCI or PRCD interrupter (portable residual current device)(not included) must be used at all times.

It is equipped with a three speed mechanical gearbox for different core drill size ranges and features a mechanical safety clutch.

The motor has electronics for soft start, overload protection and thermal (overheating) protection.

The machine is equipped with spirit levels which aid in aligning the tool. By positioning the machine so that the bubble is in the center of the window one can drill a straight hole. Use the Tubular Level for horizontal aligning.



## GROUNDING INSTRUCTIONS

### 1. All grounded, cord-connected tools:

In the event of a malfunction or breakdown, grounding provides a path of least resistance for electric current to reduce the risk of electric shock. This tool is equipped with an electric cord having an equipment-grounding conductor and a grounding plug. The plug must be plugged into a matching outlet that is properly installed and grounded in accordance with all local codes and ordinances.

Do not modify the plug provided - if it will not fit the outlet, have the proper outlet installed by a qualified electrician.

Improper connection of the equipment-grounding conductor can result in a risk of electric shock. The conductor with insulation having an outer surface that is green with or without yellow stripes is the equipment-grounding conductor. If repair or replacement of the electric cord or plug is necessary, do not connect the equipment-grounding conductor to a live terminal.

Check with a qualified electrician or service personnel if the grounding instructions are not completely understood, or if in doubt as to whether the tool is properly grounded.

Use only 3-wire extension cords that have 3-prong grounding plugs and 3 pole receptacles that accept the tool's plug.

Repair or replace damaged or worn cord immediately.

### 2. Grounded, cord-connected tools intended for use on a supply circuit having a nominal rating less than 300 V:

This tool is intended for use on a circuit that has an outlet that looks like the one illustrated in Sketch A. The tool has a grounding plug that looks like the plug illustrated in Sketch A. A temporary adapter, which looks like the adapter illustrated in Sketches B and C, may be used to connect this plug to a 2-pole receptacle as shown in Sketch B if a properly grounded outlet is not available. The temporary adapter should be used only until a properly grounded outlet can be installed by a qualified electrician. The green-colored rigid ear, lug, and the like, extending from the adapter must be connected to a permanent ground such as a properly grounded outlet box.

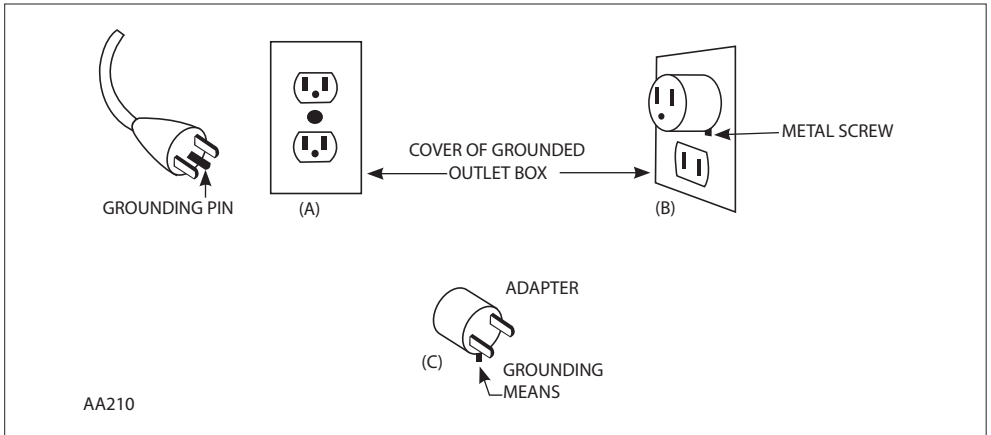

**Note: In Canada, the use of a temporary adapter is not permitted by the Canadian Electrical Code.**

## Electrical connection

The network voltage must conform to the voltage indicated on the tool name plate. Under no circumstances should the tool be used when the power supply cable is damaged. A damaged cable must be replaced immediately by an authorized Customer Service Center. Do not try to repair the damaged cable yourself. The use of damaged power cables can lead to an electric shock.

**WARNING: Always use a Residual Current Device (RCD) also known as a Ground Fault Circuit Interrupter (GFCI). Use an RCD in a separate control box with one or more socket outlets in accordance with EN 60309-2 with the earthing contact position 1 h. Always use this device whenever using the machine to reduce the risk of shock hazards. Test and reset the device before each use. Press the “Test” button to test. Press the “Reset” button to energize the circuit to the machine.**

**WARNING: Always connect the plug into the wall socket with a drip loop. If the cable leads downward directly into the wall socket, any water on the cable could run into the socket, causing a hazard.**

## ASSEMBLY

Thread the water supply assy. Into the hole in the bottom of gearbox and tighten with a wrench.

## LIST OF CONTENTS

- Diamond core drilling machine.
- Mounting spacer
- Water feed assembly
- Wrench

## OPERATING INSTRUCTIONS

### 1) MOUNTING THE CORE BIT

**CAUTION: Ensure that the threads of the spindle and the core bit match. Attempting to mount mismatched threads will result in damage to both threads.**

The spindle has two types of threads. The outside male thread is 1-1/4inch UNC, the inside female thread is 1/2 inch BSP. Ensure both the core bit and the machine spindle are clean. Any debris could cause excessive run-out of the mounted core bit. Excessive run-out can cause premature failure of the core bit and/or a safety hazard. Tighten the bit to the spindle using two wrenches. Only use correct sized wrenches to avoid damage to the spindle or bit. Torque to at least 200 newton meters

### Choosing the correct core bit for the job:

Ensure that the bit you are using is suitable for the material you are drilling. There are two main types of diamond core bit:

**Wet/dry type-electroplated (surface set) diamond core bits and wet type-sintered (impregnated) diamond core bits.**

We recommend always using wet-type (sintered) bits with this machine.

Electroplated bits, also known as wet/dry type, are only suitable for less hard materials. The diamonds are sharp and coarse and are only set on the surface. They have a much shorter service life than sintered bits and cannot be dressed (resharpened). Once they become dull, they must be replaced. They tend to work well with softer, abrasive materials like brick.

Sintered bits, also known as wet type, are much longer lasting but require operator knowledge for best results. Water is absolutely always required with sintered bits. The bit is impregnated with many layers of diamond in its metal matrix. As the matrix (bond) wears, new diamonds are exposed. If the bit becomes glazed, it can be resharpened by dressing with an appropriate alumina oxide or silicon carbide dressing stick. There are many variables with sintered diamond core bits, such as diamond grade and type, diamond grit size, bond type, bond hardness, and bit wall thickness. Consult with your diamond core bit supplier for the best bit for your application. Work materials vary widely in hardness.

### 2) WATER SUPPLY

Water is a basic requirement for diamond core drilling. The water serves as a coolant to avoid the working surface at the tip of the bit from overheating. When the diamond bit becomes overheated, both the bond matrix and even the diamonds break down. The most frequent cause of diamond core bit damage is caused by drilling without enough coolant water. Water should always be used to cool and lubricate the bit and to flush out abrasive particles formed while drilling. Never use this machine without water feed.

To connect the water supply. Attach the quick-release water coupling to a water hose.

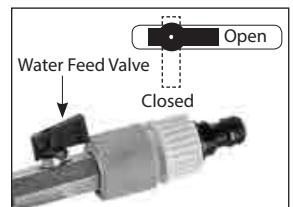

**WARNING:** Never allow water to enter the motor. It could lead to an electric shock.

**WARNING:** Check all connections of the water feed system to ensure there are no leaks. Inspect hoses and other critical parts which could deteriorate.

**WARNING:** The maximum water pressure should not exceed 70 psi (4 bar).

**CAUTION:** There is a small indicator hole on the water feed collar. If this hole leaks water, it indicates that the water seals are worn out. Replace them immediately.

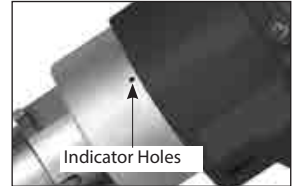

**CAUTION:** Never use this machine without water feed. Running dry will overheat and destroy its water seals.

Use a water collector with a wet vacuum to collect cooling water if nearby objects could be damaged by water.

**WARNING:** Never allow water to enter the motor. A perfectly functioning water collector set up must be used for any drilling performed at an upward angle.

### 3) SELECTING SPEEDS

There are various ranges to suit the bit size and work piece hardness. Choose the slowest speed for large diameter bits and hard materials. If when cutting the bit stalls repeatedly, then you must change to a lower gear. If you are already in the lowest gear and the bit stalls repeatedly, then you are using the machine over its maximum capacity.

**CAUTION:** Never attempt to change gears on a running machine! Only adjust when the machine is at rest.

Select the desired gear range by turning the gear selector either clockwise or counterclockwise into the desired gear. It will usually be necessary to turn the spindle by hand a little to get it to shift all the way.

#### GEAR SPEEDS

**Speed 1:**  $n_0$  550/min,  $n$  345/min

**Speed 2:**  $n_0$  1000/min,  $n$  630/min

**Speed 3:**  $n_0$  1600/min,  $n$  1000/min

#### RECOMMENDED BIT Ø

6"-12" (152-300mm)

4"-6" (102-152mm)

3/4" - 4" (20-102mm)



( Recommended bit size based on average hardness concrete. Speeds will vary with different material hardnesses. For reinforced concrete, speeds will be significantly slower.)

## 4) MOUNTING TO A DRILLING STAND (NOT INCLUDED).

**Warning: Do not attempt to mount to a rig that does not have a perfectly fitting mounting system.**

The motor has a standard four bolt pattern for attaching a mounting spacer. Use a mounting spacer suitable for the stand you are using to mount your drill motor to your stand. Tighten the four bolts evenly to 12Nm.

To mount to the stand, loosen the cradle lock bolt and place the mounting spacer squarely in the cradle. Then tighten the cradle lock bolt firmly to 17Nm.

The rig may be anchored to the work piece in one of three ways, with a mechanical anchor, with a vacuum base, or with a jack screw. (Follow the instructions provided with the rig.)

## TO INSTALL THE DRILL STAND

1. Measure the distance from the center of the intended cut to the location of the mounting slot in the base. Follow the concrete anchor manufacturer's instructions to install. Using an appropriate tool such as a rotary hammer, drill a correct sized hole to fit the anchor. Then drive in the anchor to below flush.
2. Move the base into position and screw in the anchor bolt, washer and nut, leaving it finger tight for the moment.
3. Using the bubble level, adjust the four leveling bolts to achieve a good level positioning, then fully tighten the center anchor bolt. The entire rig must be mounted solidly.

**WARNING: Never attempt to drill unless the stand is fixed securely beyond any doubt.**

## 5) THE SWITCH

This machine has a rocker switch. Press the switch to the on position to turn on. Press the switch to the off position to turn off.

**Note: 115V models have a relay type switch, if there is an interruption to the power supply, the machine will not restart when the power returns. In this case first turn the switch to the off position then back to the on position to restart.**

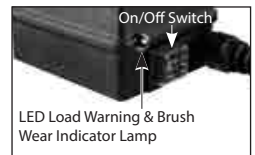

## 6) OVERLOAD PROTECTION AND OVERHEAT PROTECTION

### Overload & Load Warning Lamp:

When full load is reached and nearing overload, the load warning lamp will flash red. If full load is exceeded, the load warning lamp will glow solid red. If overload is sustained for more than 5-10 seconds, the motor will shut down and the load warning lamp will glow solid red. In this case, the motor must be first shut off and then restarted. When this happens, the motor will very likely be near overheating, so it is also a good idea to run the motor at no load for a few minutes to cool it before continuing.

### Overheat Thermal Protection:

If the temperature of the motor gets too high, the thermal protection will shut the motor down. When this happens, do not immediately start drilling after restarting the motor. Always run the machine at no load for a few minutes to return to a normal operating temperature before continuing.

**CAUTION: The motor will be damaged if it is repeatedly overloaded or overheated.**

Always cool the motor by running at no load for a few minutes whenever it stops from either overheat or overload.

## 7) SAFETY CLUTCH

This machine is equipped with a mechanical clutch to protect the operator and machine from excessive torque forces. When the preset maximum torque level is reached, the clutch will slip.

Normally, the electronic overload will operate first. But if the load is very sudden or extreme, such as when the bit gets stuck, the clutch will operate first.

After the clutch slips many times, it will become worn and slip at lower and lower torque levels.

When this happens, it must be serviced by an authorized service provider.

The recommended torque of the clutch nut is 21 Nm.

For qualified technicians, please see the instructions on p.14 "**CLUTCH REPLACEMENT**"

**CAUTION: Always ease off the load immediately whenever the clutch slips. Do not allow the clutch to continue slipping or it will wear out prematurely.**

**WARNING: When coring through a floor, the core will fall down. Take precautions to avoid injury or damage below.**

**NOTE: When drilling with a new bit for the first time, use less than normal feed pressure for a time until it breaks-in.**

## DRILLING INSTRUCTIONS

1. Press the ON button to turn the machine on.
2. Open the water valve slightly and very gently begin the cut. Use very light feed pressure to prevent the bit from wandering until the bit is fully penetrated into the cut.
3. Make adjustments to the water feed as needed. The water leaving the cut should be a solid colored slurry with about the consistency of milk. If the exiting water is clear, then you may reduce the water flow. If the exiting water is thick and muddy, then increase the water. It's very important that the water has enough pressure to flush cutting debris out of the cut.
4. Once in the cut, use steady feed pressure for about 30 seconds, then back off feed pressure for a few seconds to allow cutting debris to escape the kerf (cutting area) and for the cutting surface of the bit to cool. This has the added benefit of allowing the motor to remain within a good working temperature. Repeat this cycle until finished.
5. When the cut is almost finished and the bit is about to break through, the bit will be very liable to get stuck. Take extra care gripping the machine tightly and reduce feed pressure at this point.

**WARNING: Always keep your face away from the machine.**

**WARNING: If the rig breaks loose of its mountings, it will move to the right. (The entire assembly will rotate counterclockwise.) Avoid standing to the right of the rig and avoid operating from the right side if possible and be ready to jump out of the way in time.**

Arrange the power supply cable with minimal slack and oriented in such a way that if the machine gets out of control and spins, it will immediately unplug its own cable.

## ABOUT DIAMOND BITS

The diamond impregnated segments in a wet type (sintered) diamond core bit operate on a principle of controlled erosion. The bond matrix holding the diamonds is continually worn away by abrasion with the work piece, exposing the harder diamonds to stand proud from the bond matrix. A bit with good diamond exposure is a sharp bit.

This erosion process causes heat and particles, which require water to cool and rinse free. Without adequate water, the bit would overheat and be destroyed.

With too much water and not enough feed pressure, there would not be adequate erosion of the bond matrix (the diamonds not exposed) and the bit becomes dull (diamond segments polish smooth). This is called glazing and luckily the bit can be de-glazed (sharpened). If the bit seems to refuse to cut anymore, you know that it is glazed.

**See below: "SHARPENING A GLAZED BIT "**

Never use a sharp motion or the bit will be damaged. Conversely, don't feed too gently or the diamond segments will become glazed. Keep the bit steadily working, but don't be abusive or give the bit shock impacts into the work surface.

If the cut is very deep, the core plug may be obstructing the flow of cooling water. In this case, stop drilling, and chisel out the core plug before continuing.

**CAUTION: If the bit gets stuck, do not try to rock it loose by turning the switch on and off. That is hazardous and could damage the motor. Rather, unplug the machine and use a wrench on the bit mounting to work it loose.**

If embedded steel such as rebar is encountered take special care. When the steel is encountered, the water will generally go clear and vibration will begin. Change to a lower gear if available. Reduce the feed pressure by about 1/3 and let the bit go at its own pace, if there is too much vibration the bit will be destroyed.

Once the steel is passed, continue normally. A properly sharp bit with good diamond exposure should be able to cut through rebar if handled well.

When the cut is finished keep the motor running until the bit is removed from the cut to avoid it getting stuck.

**CAUTION: Drilling operations are very stressful to the motor and at the end of the cut, the motor temperature will be very hot, always run the motor at no load for a few minutes until the temperature returns to a normal range before shutting off. Turn the water feed down to a very small amount of flow (not off), just enough to keep the water seals from overheating when you perform this step.**

Then turn off the switch and allow the coasting bit to stop before setting it down.

## RESHARPENING A GLAZED BIT

If the bit becomes glazed, the ideal way to sharpen and true it up is by dressing with an appropriate alumina oxide or silicon carbide dressing stone. Simply drill into the stick as many times as necessary to restore its cutting performance.

If it is only slightly dull, while cutting, you may first reduce the water flow by about half until the water exiting the kerf is really muddy.

Another method is to stop and add about 6mm (1/4") of coarse silica sand in the kerf and drill for a few minutes, then turn up the water to rinse the sand free. Repeat as needed.

Another method is to drill into a cinder block. Repeat as needed.

If that still does not work the only choice is to use a dressing stone.

## VIBRATION TROUBLESHOOTING

If vibration occurs and it is not caused by embedded steel, stop drilling to find the cause and remedy.

**CAUTION: Do not operate with vibration or there will be serious hazard and the diamond core bit will surely be destroyed.**

**Vibration is usually caused by:**

1. A bit with too much runout  
**SOLUTION:** Replace bit.
2. A bit with diamond segments broken off  
**SOLUTION:** Repair or replace bit.
3. Shifted base or loose gibs  
**SOLUTION:** Retighten mountings or adjust gibs as needed.

## KEEP TOOL CLEAN

Wipe down the machine at the end of each work day with a damp cloth.

NEVER use solvents to clean plastic parts. They could possibly dissolve or otherwise damage the material. Periodically blow low-pressure compressed air through the ventilation slots with the motor running to keep the motor clean so that motor can be cooled normally.

Wear safety glasses while using compressed air.

## MAINTENANCE

Every 50 hours of operation blow compressed air through the motor while running at no load to clean out accumulated dust. (If operating in especially dusty conditions, perform this operation more often.)

To keep your diamond coring machine in top condition, periodic maintenance must be performed. In addition always check for a damaged power supply cable, check for loose fasteners and always keep alert for unusual noises and vibration when operating.

**WARNING: Never operate a damaged machine. Always tag a damaged machine and take it out of service until repairs can be made.**

**CAUTION: This machine is equipped with an oil bath gearbox. To avoid leakage of lubricating oil, whenever the gearbox is opened, the o-ring seal must be replaced with a new one.**

**CAUTION: This machine is equipped with an oil bath gearbox. If the gear oil is found to be leaking out, have the machine repaired by a qualified service center immediately. Running without sufficient oil will lead to certain damage of the gearbox.**

Maintenance which should be performed by an authorized service center, include the following:

- Replace water seals as needed.
- Replace the carbon brushes as needed



- Change the gear oil about every 100 hours of operation
- Replace the clutch discs and spring as needed.

Each year perform a full mechanical inspection, cleaning and re-lubrication.

## **CARBON BRUSH WEAR INDICATOR LAMP**

This machine is equipped with an LED lamp which will flash for 5 seconds when the machine is first switched on after the brushes are 80% exhausted, to remind the operator that the brushes need to be replaced. When the brush wear indicator flashes, it is only a reminder. It will not effect the operation of the motor. Bring the machine to an authorized service center for replacement of the brushes and to reset the brush wear indicator lamp.

Before you replace the brushes, first reset the brush indicator lamp according to the instructions below.

### **To reset (Qualified technicians only):**

1. With the machine unplugged, remove the 4 screws to open the switch box.
2. On the electronics board, locate the small component labeled SW1/SW2 which has 3 conductors. There is a small black bridge which will be positioned in the SW1 position, bridging the middle and righthand conductors.
3. Carefully slide the bridge up and away and then re-position the bridge on the SW2 position, bridging the middle and lefthand conductors.
4. Temporarily reclose the switch box, then plug the machine in and switch it on. It will not run, but after 5 seconds, the brush wear indicator lamp will flash rapidly. This indicates that it has been reset.
5. Unplug the machine and reopen the switchbox. Re-position the bridge on the original SW1 position, bridging the middle and righthand conductors.
6. Reassemble the switch box. It is now reset. Now replace the brushes.

## **THE CARBON BRUSHES**

The carbon brushes are a normal wearing part and must be replaced when they reach their wear limit. This machine is equipped with auto-stop carbon brushes. If the machine comes to a stop unexpectedly, the brushes should be checked. The auto-stop brush design protects the motor by stopping the machine before the carbon brushes are completely worn out.

**Caution: Always replace the brushes as a pair.**

### **To replace:**

1. Remove the 4 screws and remove the motor tail cover.
2. Using pliers rotate the brush spring out of the way and slide the old carbon brush out of the brush holder.
3. Unscrew the screw to remove the brush lead. The old carbon brush may now be lifted away.
4. Install a new brush. Installation is the reverse of removal.
5. Replace the motor tail cover. Take care not to pinch any wires when reassembling.

## **CLUTCH REPLACEMENT**

1. Support the unit in the nose-down position and remove the motor from the gearbox as follows.
2. Remove the 4 socket headed screws.
3. Separate the motor, together with the gear plate from the gearbox and lift away. Use an appropriate tool in the provided slots if separation is difficult. Take care not to damage the gasket.
4. Check the gasket and replace if it shows signs of damage.
5. Lift away the clutch gear input shaft assembly.
6. Place the input shaft in the holding fixture and loosen the nut (it is a standard right-hand thread).
7. Disassemble the clutch gear assembly and note the order and orientation of all parts for reassembly.
8. Replace the bronze clutch discs as supplied in the clutch service kit . (The clutch service kit includes 3 bronze clutch discs , 1 thin pressure disc and 1 disc spring.) Note: All parts must be pre-lubricated with clean gear oil.
9. Place the pressure disc (38) with the notch facing the input shaft pinion (43).
10. Add the first bronze clutch disc.
11. Add the bronze bushing (42).
12. Mount the clutch gear (41) with the flat side toward the input shaft (43).
13. Add the second bronze clutch disc with the tabs engaging the slots in the concave recess in the clutch gear (41).
14. Add the thin pressure disc and ensure that it fully seats.
15. Add the third bronze clutch disc.
16. Add the pressure disc (38) with the notch facing the gear.
17. Add the disc spring with the concave side facing the gear and the convex side facing outward.
18. Add a drop of thread locker such as Loctite blue and thread on the nut (36).
19. Place the input shaft in the holding fixture and torque to 21 Nm (15.5 ft-lb) in one smooth pull.
20. To test the actual slippage torque of the assembled clutch assembly, place in the holding fixture and use the special torque wrench adapter socket which engages the clutch gear and test the slippage torque with a dial torque meter. It should be within 230-300kg-cm (17-22 ft-lb).
21. Replace the clutch gear input shaft assembly If the oil is being changed at the same time, add 625cc (21.1 oz) of the specified type of gear oil (Shell Spirax S2A 80W-90 (API grade GL5) or equivalent).
22. Rejoin the motor to the gearbox and evenly tighten the 4 screws in a diagonal pattern and torque to 12 Nm.(8.8 ft-lb).

**If the replacement of the power supply cord is necessary, this has to be done by the manufacturer or their agent in order to avoid a safety hazard.**

**WARNING: All repairs must be entrusted to an authorized service center.** Incorrectly performed repairs could lead to injury or death.

Do not throw electric power tools into the household waste! In accordance with the European Directive 2002/96/EG on Waste Electrical and Electronic Equipment and transposition into national law, used electric power tools must be collected separately and recycled in an environmentally friendly manner.

# WIRING

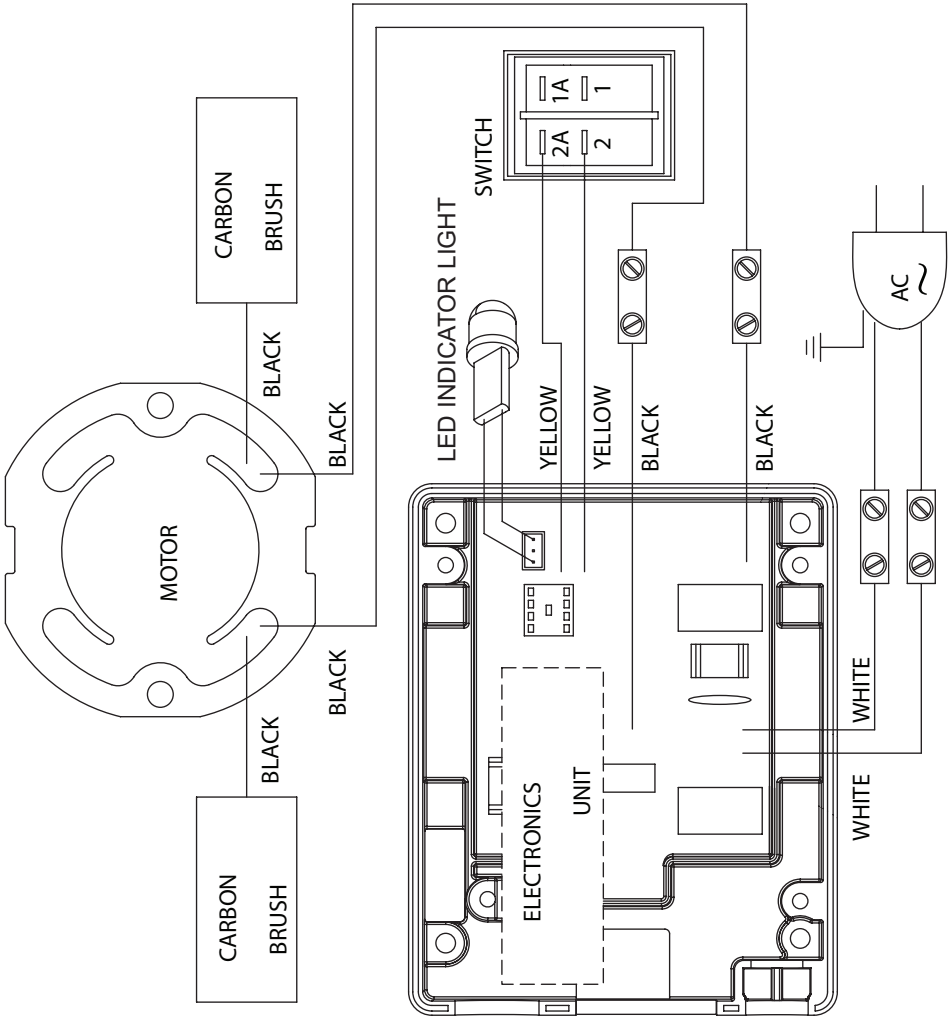

# MODEL : CB733 / 3 Speed Diamond Core Drill

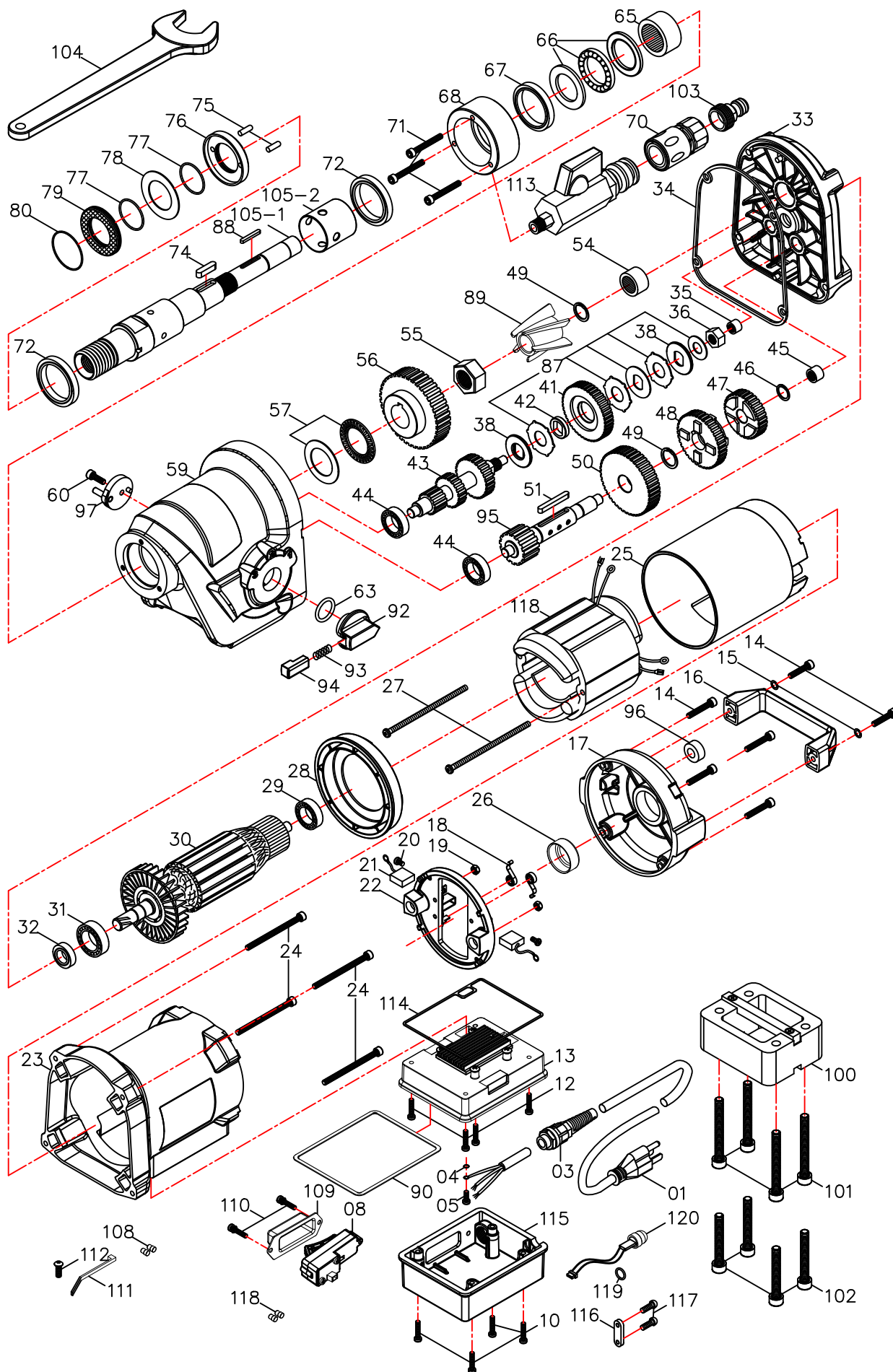

ITEM	DP #	DESCRIPTION	QTY
1	2709083	POWER SUPPLY CABLE UL-14A x 3C x 3.5M-SJTW	1
3	2700000	CORD ARMOR	1
4	6078432	EXTERNAL STAR WASHER M4	1
5	2709001	PANHEAD MACHINE SCREW M4 x 10	1
8	2709002	SWITCH 110V	1
10	2709004	PANHEAD TAPPING SCREW M4 x 25	4
12	2709006	PANHEAD MACHINE SCREW M4 x 12	4
13	2709084	ELECTRONICS UNIT 110V	1
14	2709008	SOCKET CAP SCREW M5 x 25	6
15	2709009	FLAT WASHER - 5 x - 12 x 1	2
16	2709010	TOP HANDLE	1
17	2709011	MOTOR END CASTING	1
18	6078411	BRUSH SPRING 0.4 x 4 x 3T	2
19	2709012	NYLOCK NUT M5	2
20	2709013	PANHEAD MACHINE SCREW M4 x 6	2
21	6078414	CARBON BRUSH 7x17x19 110V	2
22	2709014	BRUSH HOLDER PLATE ASSY.	1
23	2709015	MOTOR HOUSING	1
24	2709016	SOCKET CAP SCREW M6 x 75	4
25	2709017	MOTOR INSULATION SLEEVE	1
26	2710319	RUBBER BEARING SLEEVE	1
27	2709019	PANHEAD MACHINE SCREW M5 x 110	2
28	2709020	FAN SHROUD	1
29	6078427	BALL BEARING 6200	1
30	2709021	ARMATURE 110V-100 x 54.1 x 75)	1
31	6078430	BALL BEARING 6202	1
32	2709022	OIL SEAL - 14 x - 25 x 7	1
33	2709023	GEAR PLATE	1
34	2709024	GASKET	1
35	2709025	NEEDLE BEARING HK 0810	1
36	2709026	CLUTCH NUT M12 x P1.75 x 9T	1
38	2709027	PRESSURE DISC Ø34.8 x Ø16 x 2.5	2
41	2709028	INPUT GEAR M1.25 x 44T	1
42	2709029	BUSHING - 15.9 x - 22 x 4.7	1
43	2709085	INPUT SHAFT M1.5 x 27T x M1.5 x 20T x M1.5 x 13T	1
44	2709031	BALL BEARING 6200	2
45	2709032	NEEDLE BEARING HK 1010	1
46	2709086	INTERNAL CIRCLIP IS14	1
47	2709087	COUNTERSHAFT SET	1
48	2709088	SPINDLE GEAR M1.5 x 38T	1
49	2709033	INTERNAL CIRCLIP IS18	2
50	2709089	LAY GEAR M1.5 x 45T	1
51	2709090	PARALLEL KEY 5 x 5 x 40	1
54	2709039	NEEDLE BEARING TA1815	1
55	2709091	NYLOCK NUT M20	1
56	2709092	OUTPUT GEAR M2.0 x 35T	1
57	2709044	THRUST BEARING NTB3047 + AS3047	1
59	2709093	GEAR HOUSING	
60	2709094	SOCKET CAP SCREW M5 x 12	

ITEM	DP #	DESCRIPTION	QTY
63	2709047	O-RING Ø20 x 3	
65	2709048	NEEDLE BEARING TA3020	1
66	2709049	THRUST BEARING 51106	1
67	2709050	OIL SEAL Ø40 x Ø50 x 7	1
68	2709051	WATER FEED COLLAR	1
70	6078471	WATER COUPLING	1
71	2709054	SOCKET CAP SCREW M5 x 40	3
72	2709055	OIL SEAL Ø40 x Ø52 x 7	2
74	2709096	PARALLEL KEY 6 x 6 x 25	1
75	2709056	DOWEL PIN Ø4 x 11.8	2
76	2709057	ANTI-SEIZE CUP	1
77	2709058	O-RING Ø32 x 1.5	2
78	2709059	THRUST RING 3252	1
79	2709060	ANTI-SEIZE RING	1
80	2709061	O-RING Ø49 x 1.5	1
87	2709063	CLUTCH DISC SET	1
88	2709097	PARALLEL KEY 4 x 4 x 30	1
89	2709098	OIL IMPELLER	1
90	2709064	GASKET	1
92	2709065	GEAR SELECTOR	1
93	2709066	SPRING Ø0.6 x Ø3.8 x Ø5 x 11T x 35L	1
94	2709067	RELEASE PIN	1
95	2709100	COUNTERSHAFT SET	1
96	2709070	BULLS-EYE LEVEL	1
97	2709101	SELECTOR DISC	1
100	2709075	EXTENSION SPACER	1
101	2903249	SOCKET CAP SCREW M8x80	4
102	290	SOCKET CAP SCREW M8x	4
103	6078472	FITTING	1
104	2709103	WRENCH M32	1
105	2709095	SPINDLE 1-1/4"-7 x 1/2" BSP - 296.5MM (105-1 / 105-2)	1
108	2903249	BUTT SPLICE CONNECTORS	4
109	2709003	SWITCH BOOT	1
110	2709727	PANHEAD TAPPING SCREW-B M4x12	2
111	2710314	ZIP TIE TCVS-170	1
112	6078735	PANHEAD TAPPING SCREW-B M4x16	1
113	2709052	WATER FEED CONNECTOR KIT 1/2"	1
114	2710315	GASKET	1
115	2709107	COVER 110V	1
116	2710316	CABLE CLIP	1
117	6078728	PANHEAD TAPPING SCREW-B M4x14	2
118	2709018	STATOR 110V	1
119	2710317	O-RING Ø6x1)	1
120	2710318	LED INDICATOR LIGHT	1

# CB733 TOOLS

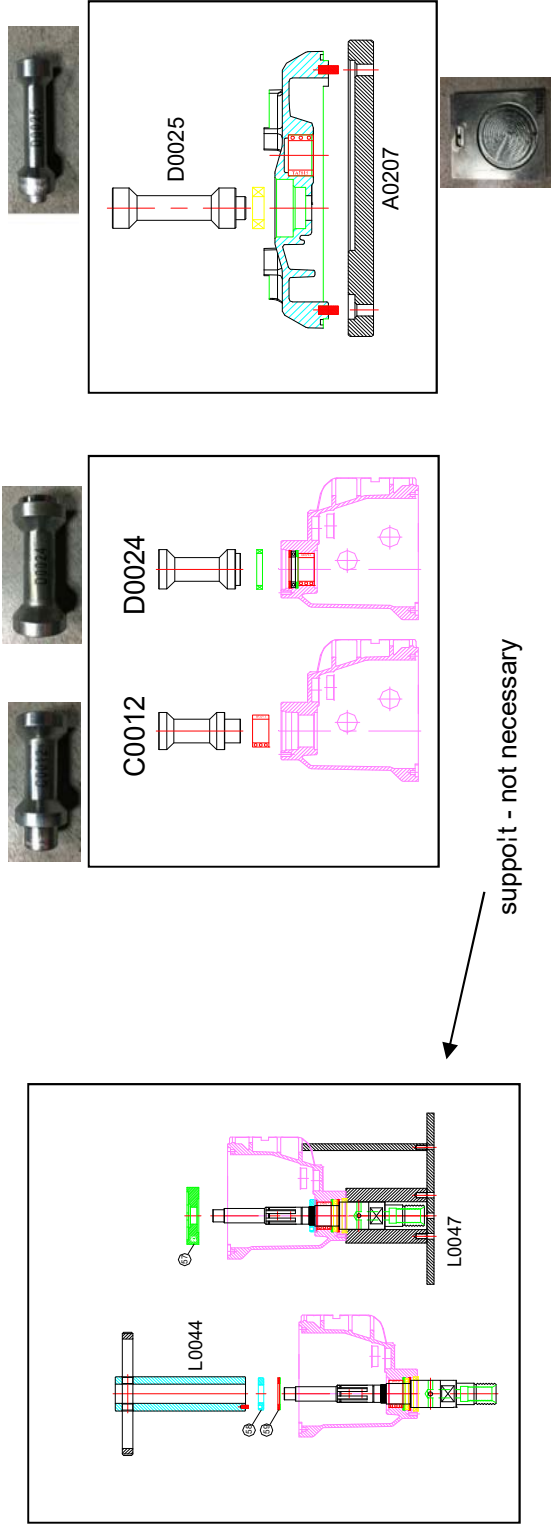

CB744		DP PART #	DESC	VEN#
No.				
1	2708429		Gear box needle bearing jig	C0012
2	2708430		Gear box oil seal jig	D0024
3	2708431		Gear plate oil seal jig	D0025
4	2708432		Gear plate seat jig	A0207
5	2708433		Spindle nut jig clutch	L0044







## **EQUIPMENT AND PARTS WARRANTY**

Diamond Products warrants all equipment manufactured by it against defects in workmanship or materials for a period of 1 year from the date of shipment to Customer. The responsibility of Diamond Products under this Warranty is limited to replacement or repair of defective parts at Diamond Products' Elyria, Ohio factory, or at a point designated by it, of such parts as shall appear to us upon inspection at such parts, to have been defective in material or workmanship, with expense for transportation and labor borne by Customer. In no event shall Diamond Products be liable for consequential or incidental damages arising out of the failure of any Product to operate properly.

THIS WARRANTY IS IN LIEU OF ALL OTHER WARRANTIES, EXPRESSED OR IMPLIED, AND ALL SUCH OTHER WARRANTIES ARE HEREBY DISCLAIMED.



333 Prospect Street, Elyria, Ohio 44035  
(440) 323-4616 • (800) 321-5336 • Fax (800) 634-4035  
[www.diamondproducts.com](http://www.diamondproducts.com)