



CONCRETE SAW PARTS LIST

MODEL CC150XL-EE

May 2015

Part # 1802416

Intentionally Blank

Table of Contents

<u>Description</u>	<u>Page No.</u>
Frame Assembly.....	4
Carriage Assembly.....	5
Motor Assembly.....	6
Blade Shaft Assembly.....	7
Spring Box Assembly 6”	8-9
Pointer Assembly.....	10
Warranty.....	12

Quick Reference Replacement/Service Parts

<u>DP Part No.</u>	<u>Description</u>
2505236	Skid Plate - 6/8” Blade - .156 Slot
2500380	(1) V-Belt-3V300

FRAME ASSEMBLY: 6040378

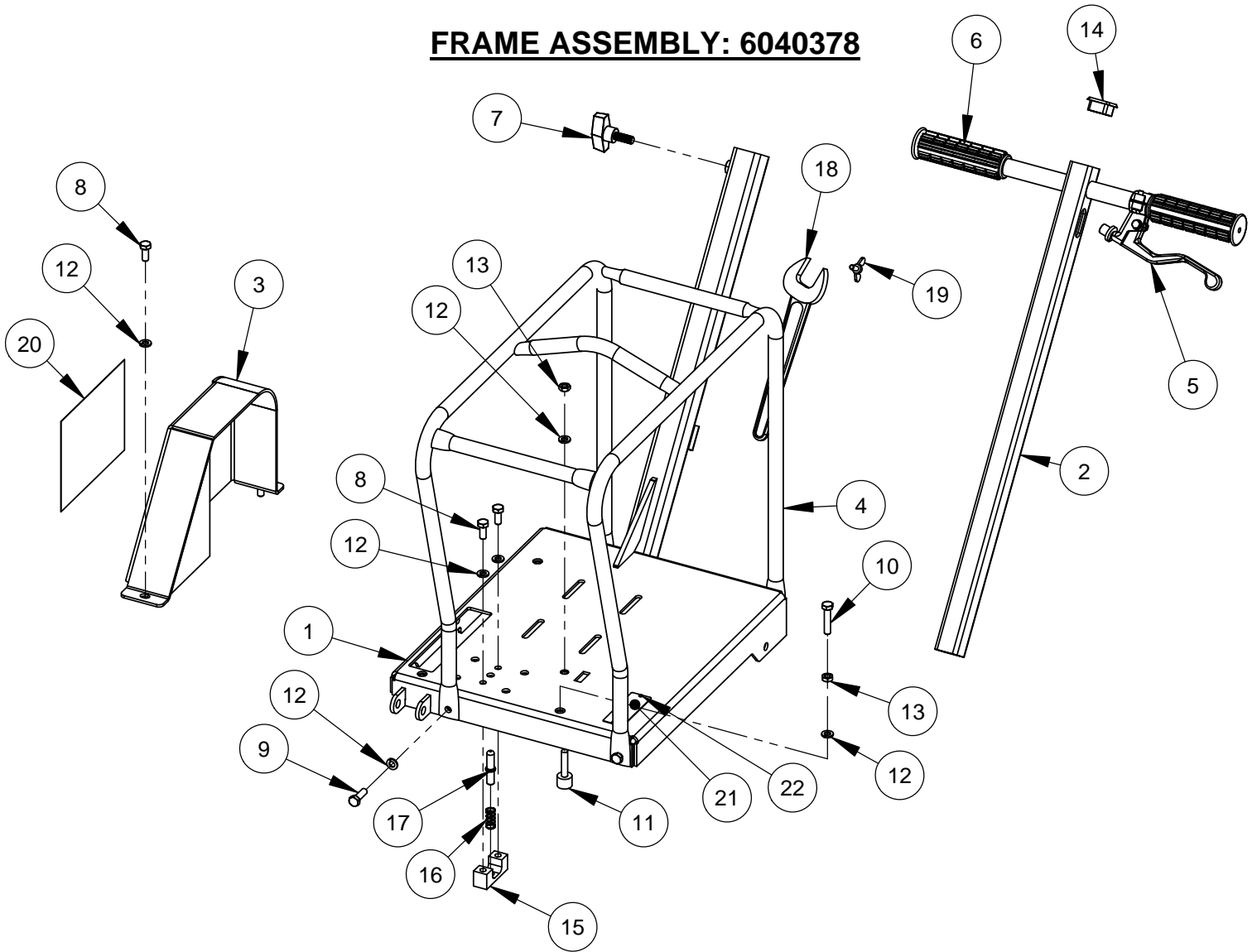

ITEM	PART NO.	QTY.	DESCRIPTION
1	6040748	1	Frame Weldment
2	6040749	1	Handle Weldment
3	6040755	1	Guard, Belt
4	6040615	1	Lift Cage
5	6010619	1	Bracket, Handlebar Lever
6	2500001	2	7/8" Handle Grip
7	2503942	1	T Handle Locking Knob /w 3/8-16 Stud
8	2900019	4	Cap Screw, Hex Hd., 5/16-18 x 3/4"
9	2900138	4	Cap Screw, Hex Hd., 5/16-18 x 1"
10	2900508	1	Cap Screw, Hex Hd., 5/16-18 x 1-1/2"
11	2504808	1	Bumper w/ 5/16-18 threaded stud
12	2900031	10	Lock Washer, 5/16" Split
13	2900283	2	Jam Nut, 5/16-18
14	2503823	1	Plug, 1-1/4 Square Tube
15	6040560	1	Blade Stop Block
16	2501192	1	Spring, Comp. .48 x .042 x 1.00 Long
17	6040561	1	Blade Stop
18	2500256	1	Wrench, 1-1/16" Open End
19	2900307	1	Wing Screw, M6 x 16mm
20	1802419	1	CC150XL Core Cut Decal
21	1800169	1	Serial Number Plate, US
22	2900053	2	Rivet, 3/32" Dia.

CARRIAGE ASSEMBLY: 6040379

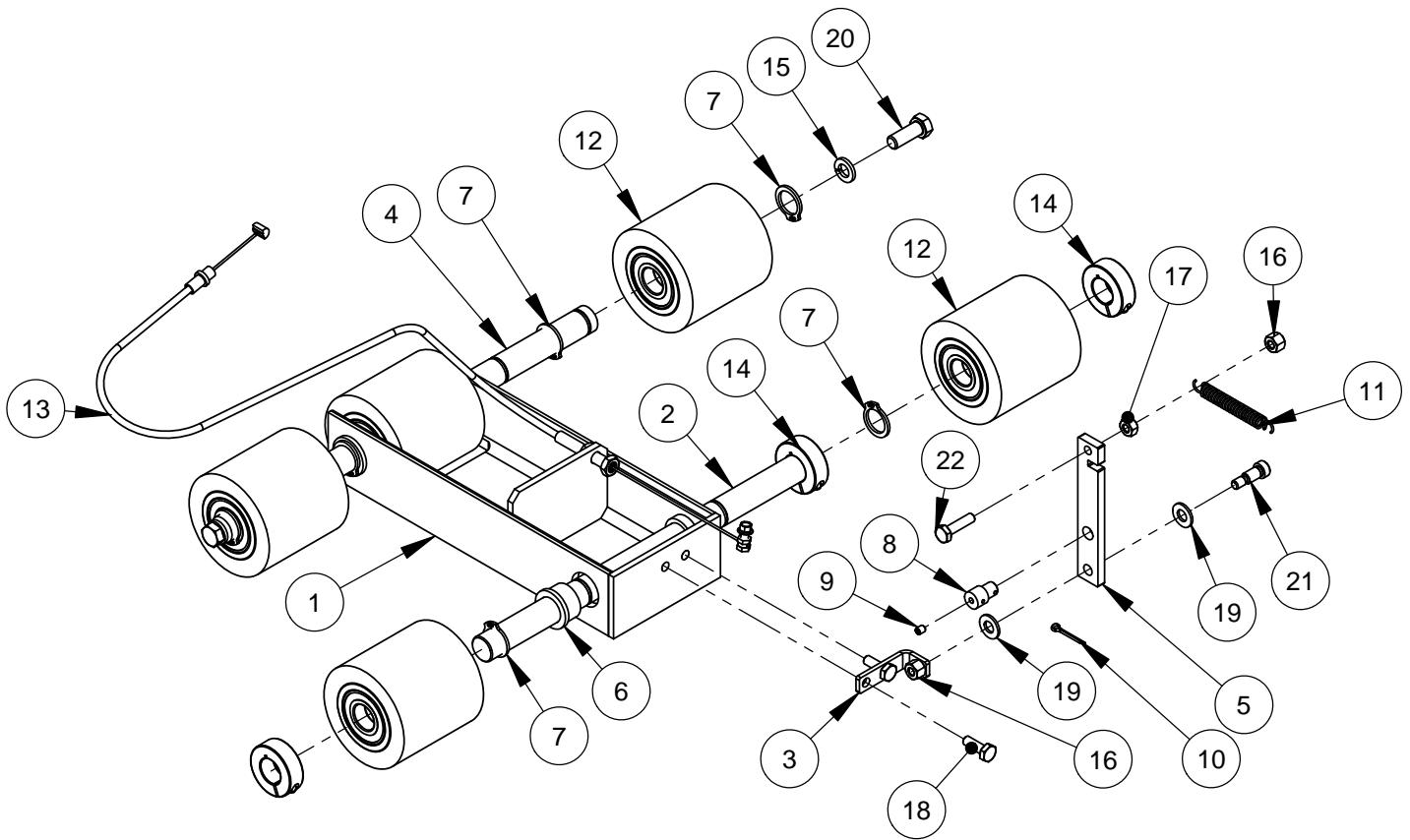

ITEM	PART NO.	QTY.	DESCRIPTION
1	6040750	1	Axle Weldment
2	6040751	1	Shaft, Front Axle
3	6040754	1	Bracket, Lift
4	6040549	1	Shaft, Rear Axle
5	6040550	1	Lift Plate
6	2503189	4	Bearing, Flanged Bronze 3/4 ID
7	2504805	8	Retaining Ring, .75 Ext. Heavy Duty
8	6048212	1	Pivot Pin
9	2900059	1	Set Screw, Soc. Hd., #10-32 x 1/4"
10	2900034	1	Cotter Pin, 3/32" x 3/4"
11	2500066	1	Spring, Ext 3/8 X .055 X 5"
12	2503641	5	Wheel 3 X 3 X 3/4" Poly
13	2506324	1	Cable Assembly
14	2504577	3	Shaft Collar, 3/4" Split
15	2900006	2	Lock Washer, 3/8" Split
16	2900010	4	Lock Nut, 1/4-20 Nylon
17	2900125	1	Hex Nut, 1/4-20
18	2900144	2	Cap Screw, Hex Hd., 1/4-20 x 3/4"
19	2900022	2	Flat Washer, 5/16" SAE
20	2900005	2	Cap Screw, Hex Hd., 3/8-16 x 1"
21	2900051	1	Shoulder Screw, 5/16" x 1/2" (1/4-20)
22	2900008	1	Cap Screw, Hex Hd., 1/4-20 x 1"

**MOTOR ASSEMBLY: 6040350-HONDA
6040727- BRIGGS
6040590-LIFAN**

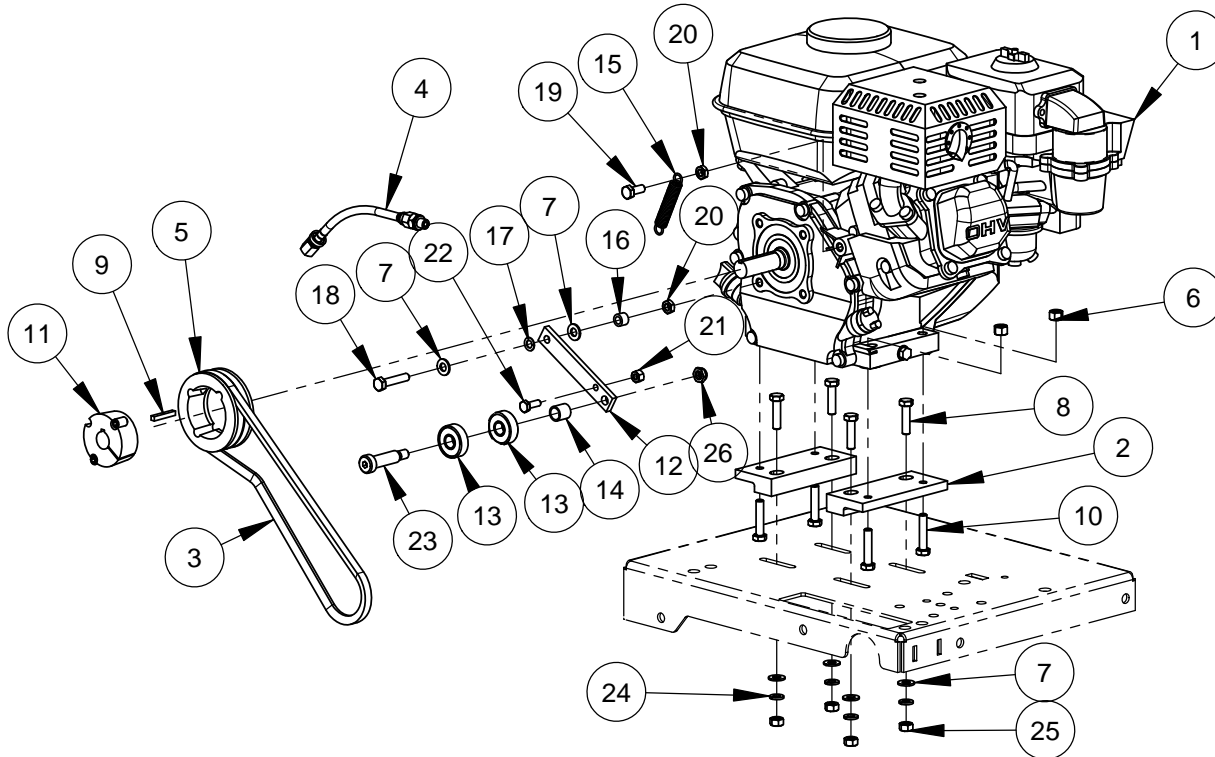

ITEM	PART NO.	QTY.	DESCRIPTION
1	2600091	1	Engine, Honda 4.8 HP (GX160)
	2600601	1	Engine, Briggs & Stratton 5.5HP
	2601708	1	Engine, Lifan LF168F
2	6030051	2	Mount, Engine Honda GX160
3	2500380	1	V-Belt, 3VX300
4	6030108	1	Oil Drain Assembly (Honda & Lifan)
	6030249	1	Oil Drain Assembly (Briggs)
5	2504694	1	Sheave, 3.35-2 Groove (2-3V-3.35-TB)
6	2900039	4	Lock Nut, 5/16-18 Nylon
7	2900022	6	Flat Washer, 5/16" SAE
8	2900217	4	Cap Screw, Hex Hd., 5/16-18 x 1-1/4"
9	6048229	1	Key, 3/16" Sq. x 1-1/4"
10	2900508	4	Cap Screw, Hex Hd., 5/16-18 x 1-1/2"
11	2501191	1	Taper Bushing, 3/4" w/ Set Screws
12	6040562	1	Plate, Belt Tensioner
13	2502276	2	Ball Bearing, 1/2 x 1-3/8 x 7/16 (1621-ZZ)
14	6040563	1	Bushing, Steel 1/2 ID x 5/8 OD x 5/8 Long
15	2503190	1	Spring, Ext..48 x .063 x 3.00 Long
16	2503191	1	Bearing, Bronze SS-1016-6
17	2900889	1	Friction Washer, 5/16"
18	2900945	1	Cap Screw, Hex Hd., 5/16-24 x 1-1/2"
19	2900589	1	Cap Screw, Hex Hd., 5/16-24 x 3/4"
20	2900049	2	Jam Nut, 5/16-24
21	2900010	1	Lock Nut, 1/4-20 Nylon
22	2900144	1	Cap Screw, Hex Hd., 1/4-20 x 3/4"
23	2900826	1	Shoulder Screw, 1/2" x 1-1/2" (3/8-16)
24	2900031	4	Lock Washer, 5/16" Split
25	2900141	4	Hex Nut, 5/16-18
26	2903246	1	Jam Lock Nut, 3/8-16

BLADE SHAFT ASSEMBLY: 6040380

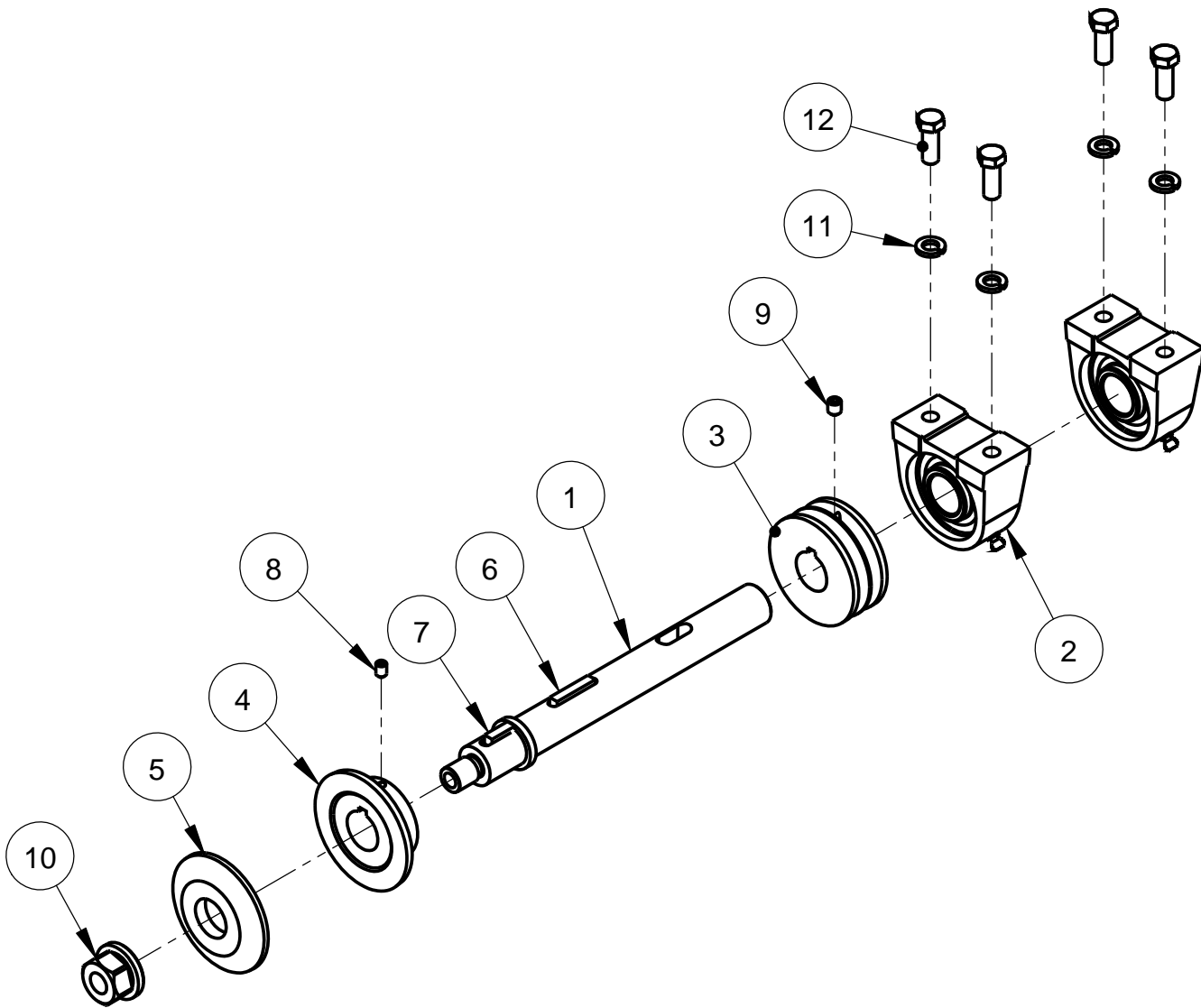

ITEM	PART NO.	QTY.	DESCRIPTION
1	6040752	1	Blade Shaft
2	2500732	2	Pillow Block Bearing 1"
3	6041067	1	Sheave, 3V-2GR, 3"
4	6041069	1	Flange, Inner Blade 3"
5	6041070	1	Flange, Outer Blade 3"
6	6010169	1	Key, 1/4" Sq. x 1-1/4"
7	6040081	1	Key, 1/4" Sq. x 3/4"
8	2900101	1	Set Screw, Soc. Hd., 1/4-20 x 3/8"
9	2900142	1	Set Screw, Soc. Hd., 5/16-18 x 3/8"
10	2900065	1	Flange Nut, 5/8-11 R.H.
11	2900006	4	Lock Washer, 3/8" Split
12	2900005	4	Cap Screw, Hex Hd., 3/8-16 x 1"

SPRING BOX ASSEMBLY # 6040664

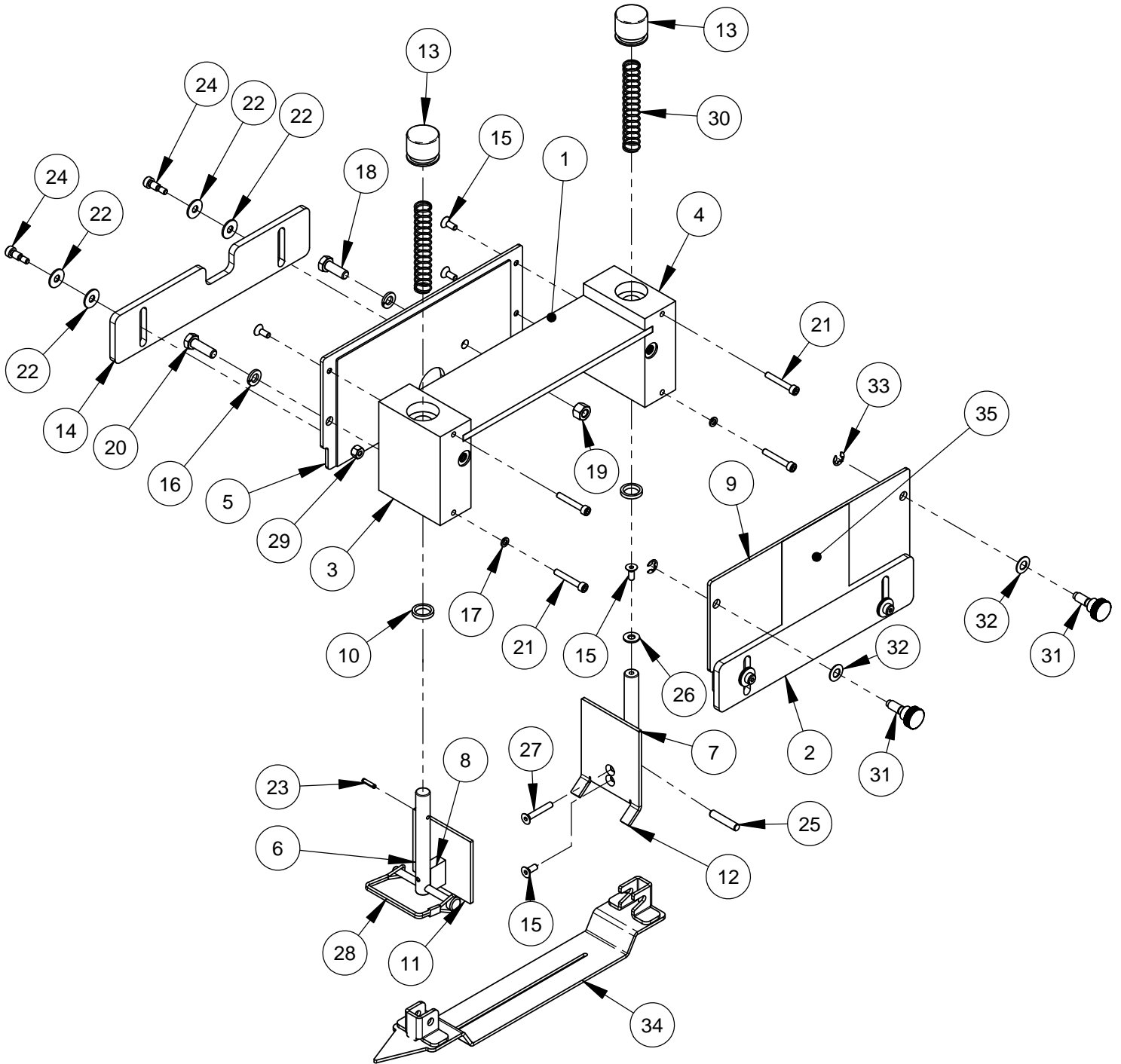

Assembly Note:

1. Apply 2502046 synthetic grease to OD of compression springs

SPRING BOX ASSEMBLY # 6040664

ITEM	PART NO.	QTY.	DESCRIPTION
1	6040655	1	Cover, Top Spring Box
2	6040662	1	Cover, Outer Lexan
3	6040654	1	Spring Block, Rear 6"
4	6040653	1	Spring Block, Front 6"
5	6040652	1	Cover, Inner Spring Box
6	6040658	1	Shaft, Spring Block Rear
7	6040657	1	Shaft, Spring Block Front
8	6040659	2	Block, Dust Diverter
9	6040651	1	Cover, Outer Spring Box
10	2504593	2	Shaft Seal, 1/2" Shaft
11	6040661	1	Diverter, Rear Dust
12	6040660	1	Diverter, Front Dust
13	6040656	2	Spring Block Cap
14	6040663	1	Cover, Inner Lexan
15	2900456	6	Cap Screw, Flat Hd., #10-32 x 1/2"
16	2900031	2	Lock Washer, 5/16" Split
17	2900038	2	Lock Washer, #10 Split
18	2900668	1	Cap Screw, Hex Hd., 5/16-18 x 7/8"
19	2900039	1	Lock Nut, 5/16-18 Nylon
20	2900138	1	Cap Screw, Hex Hd., 5/16-18 x 1"
21	2901584	4	Cap Screw, Soc. Hd., #10-32 x 1-1/4"
22	2901585	8	Flat Washer, 1/4" Nylon
23	2901586	1	Roll Pin, 1/8 Dia. x 9/16"
24	2901587	4	Shoulder Screw, 1/4" x 3/8" (#10-24)
25	2900577	1	Dowel Pin, 1/4" Dia x 1-1/4"
26	2900016	1	Flat Washer, #10 USS
27	2907093	2	Cap Screw, Flat Hd., #10-32 x 1-1/4"
28	2901589	1	Pin, Safety 1/4"
29	2900017	4	Lock Nut, #10-24 Nylon
30	2504643	2	Spring, Comp. .60 x .045 x 3.50 Long
31	6040385	2	Captive Thumb Screw, 5/16-18
32	2901963	2	Washer, Belleville 5/16"
33	2504645	2	Retaining Ring, 5/16 Ext.
34	2505236	1	Skid Plate Weldment-6/8" Blade -.156 Slot
35	1802443	1	DP Symbol Decal
36	2502046	AR	Grease, Fuchs Synthetic

POINTER ASSEMBLY: 6041088

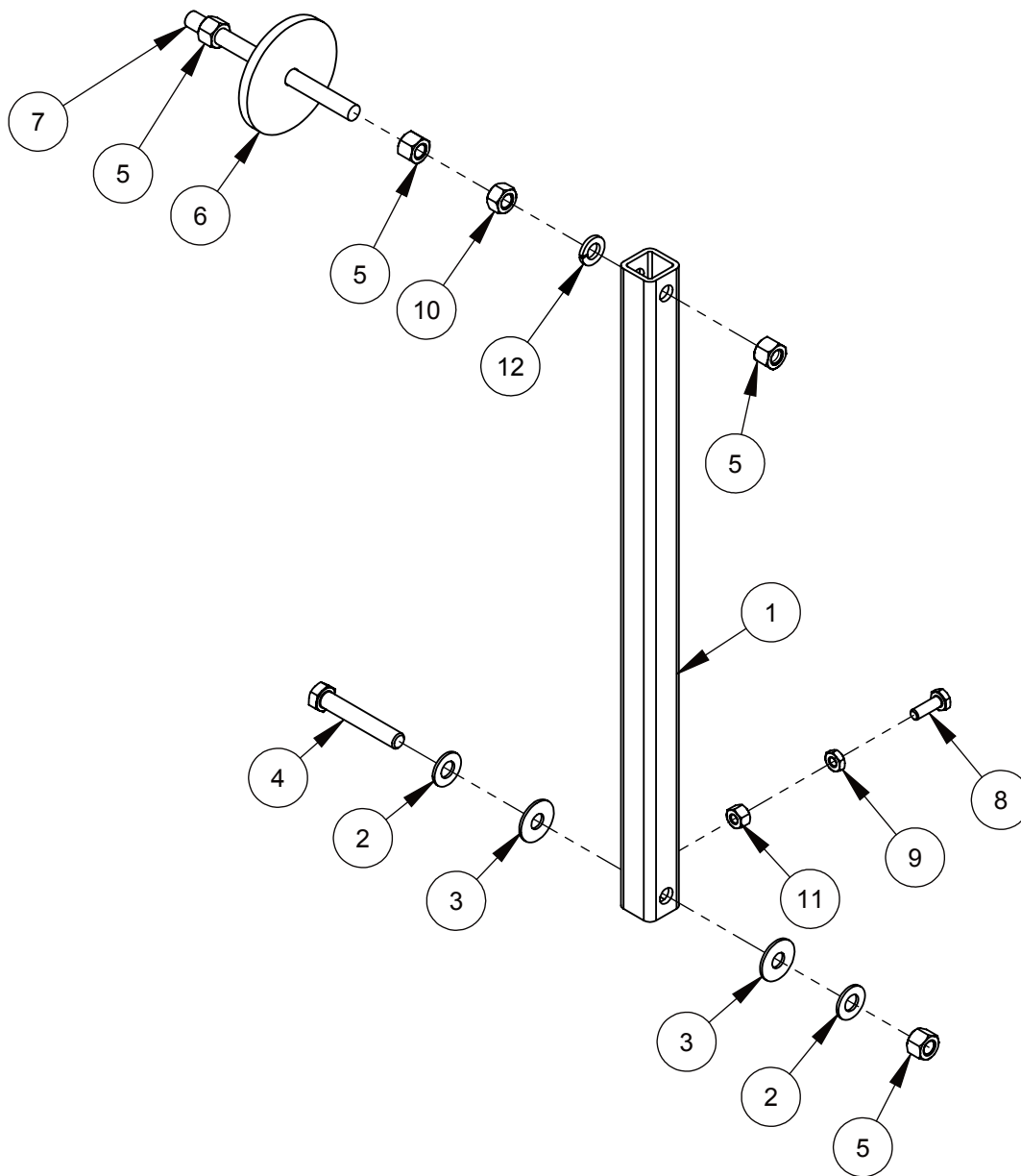

ITEM	PART NO.	QTY.	DESCRIPTION
1	6041085	1	Pointer
2	2900014	2	Flat Washer, 3/8" SAE
3	2900153	2	Friction Washer, 3/8"
4	2900079	1	Cap Screw, Hex Hd., 3/8-16 x 2-1/4"
5	2900018	4	Lock Nut, 3/8-16 Nylon
6	6041086	1	Guide Wheel
7	6041087	1	3/8-16 X 5.00" Threaded Rod
8	2900144	1	Cap Screw, Hex Hd., 1/4-20 x 3/4"
9	2900358	1	Jam Nut, 1/4-20
10	2900033	1	Hex Nut, 3/8-16
11	2900010	1	Lock Nut, 1/4-20 Nylon
12	2900006	1	Lock Washer, 3/8" Split

Intentionally Blank

EQUIPMENT AND PARTS WARRANTY

Diamond Products warrants all equipment manufactured by it against defects in workmanship or materials for a period of one (1) year from the date of shipment to Customer.

The responsibility of Diamond Products under this Warranty is limited to replacement or repair of defective parts at Diamond Products' Elyria, Ohio factory, or at a point designated by it, of such parts as shall appear to us upon inspection at such parts, to have been defective in material or workmanship, with expense for transportation and labor borne by Customer.

In no event shall Diamond Products be liable for consequential or incidental damages arising out of the failure of any Product to operate properly.

Integral units such as engines, electric motors, batteries, transmissions, etc., are excluded from this Warranty and are subject to the prime manufacturer's warranty.

THIS WARRANTY IS IN LIEU OF ALL OTHER WARRANTIES, EXPRESSED OR IMPLIED, AND ALL SUCH OTHER WARRANTIES ARE HEREBY DISCLAIMED.

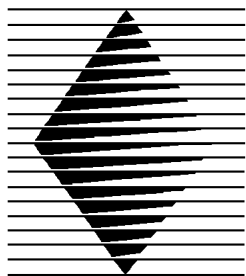

DIAMOND PRODUCTS

333 Prospect Street, Elyria, Ohio 44035
(440) 323-4616 • (800) 321-5336 • Fax (440) 323-8689
www.diamondproducts.com